

Miller Curber *Co.LLC*

Curbiders®



Stands the test of time™



Product Overview

For over fifty years the Miller MC Series Curbuilders have offered unequalled performance and versatility for the placement of free-standing curb. These simple and efficient self-propelled machines operate on the extrusion principle and provide the most economical means available of constructing small to mid-sized continuous curb from either concrete or asphalt. This quick and efficient process drastically reduces the high labor costs associated with hand formed and poured curb and produces high quality, extremely dense curb at a rate of up to 15 fpm (up to 30 fpm for MC900). Miller's interchangeable extrusion auger assemblies give each Curbuilder the capacity to extrude more shapes and sizes than any machine in its class, from 4" to 18" high curb. A wide variety of options allow these machines to meet the toughest specification work.



MC550/650 with Wheelbarrow Hopper

Miller Advantages

- Every model will extrude concrete or asphalt
- Four interchangeable extrusion assemblies with auger diameters from 5" to 10"
- Available with reversible hopper for quick change from right to left side extrusion, or with WB hopper to accept full size wheelbarrow
- Extrude steel rod through the curb center (optional hollow auger assembly)
- Two-piece 5", 6" and 8" cast augers allowing four separate wear surfaces for extended life
- Easy access and removal of all extrusion components for maintenance and quick clean-up
- Nearly 2,000 curb choices with custom shapes available at no additional cost
- Typically ships within one week of ordering



MC900

A Sample of the Nearly 2,000 Curb Designs

Use the following chart as a guide to determining the proper auger.

Auger Size	Cross Sectional Area		Height		Width	
	Min	Max	Min	Max	Min	Max
5"	18 sq. in.	35 sq. in.	4"	6"	5"	9"
6"	36 sq. in.	55 sq. in.	5"	10"	6"	14"
8"	56 sq. in.	119 sq. in.	7"	18"	8"	18"
10" *	120 sq. in.	220 sq. in.	8"	18"	10"	18"

* MC850 and MC900 only

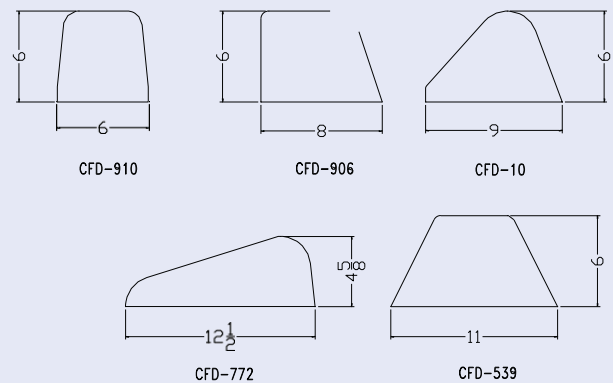

A high percentage of extruded curbs have a cross sectional area between 33 and 55 square inches, so every Miller Curbuilder is equipped with the 6" extrusion assembly as standard equipment. Assemblies of other sizes are available and can easily be retrofitted to machines in the field. Each assembly is complete and includes auger, auger shaft, auger housing, compaction tube, bearings and driven sprocket.

PRODUCT SPECIFICATIONS



	MC550	MC650	MC850	MC900
Operating Weight	668 lb.	718 lb.	918 lb.	959 lb.
Height (steering handle down)	38"		38"	40.5"
Width	32.25"		32.25"	32.25"
Length with Form (steering handle up)	77.5"		77.5"	91.5"
Wheelbase	52.75"		52.75"	71"
Hopper Capacity (Reversible/WB)	6.1 / 7.6 cubic feet		6.1 / 7.6 cubic feet	
Standard Tire Configuration	(9) 8" dia. x 2" solid rubber		(9) 8" dia. x 2" solid rubber	
Engines	13 HP Honda 14 HP Kohler		20.3 HP Honda	
Engine Starting System	Recoil	Electric	Electric	Electric
Fuel Capacity	1.6 gal.		2.3 gal.	
Standard Auger Configuration	(2) cast 6" dia. x 9" lg.		(3) cast 6" dia. x 9" lg.	
Optional Auger Configurations	(2) cast 5" dia. x 9" lg. (2) cast 8" dia. x 9" lg.		(2) cast 5" dia. x 9" lg. (2) cast 8" dia. x 9" lg. (1) welded 10" dia. x 18" lg.	
Hollow Auger Shaft (to extrude rebar)	Optional		Optional	
Drive System	Automatic centrifugal clutch to enclosed 8:1 gear reducer; final auger drive chain & sprocket Extrusion process provides self-propulsion			
Steering	Tie rod with 40" steering handle			
Brake	Friction pad on steering handle			

OTHER AVAILABLE MODELS:

MC655 Same as MC650, but with modified frame allowing extrusion under existing guardrail.

MC750 Same as MC650, but with two continuously turning auger assemblies, one mounted on the left and one on the right, allowing immediate changeover from right to left hand extrusion.

Landscape Curbilders®

PRODUCT OVERVIEW Two different machine models are available to meet small curb requirements, from decorative landscape borders to small tack-down commercial applications. Either the **MC250** extrusion machine, or the **MC350** reciprocating plunger machine, will produce high-quality, free-standing concrete curb.

Both machines feature:

- Console-mounted emergency stop
- Hour-service meter
- Level indicator
- Multi-position steering handle
- Lifting bail

MC250 features:

- Superior speed, curb-density, and strength due to extrusion process.
- Ideally suits both decorative borders and small commercial applications
- Continuous speeds to 10 fpm

MC350 features:

- Reversible curb forms for left or right curb placement
- Simple disassembly for cleanup
- Reduced maintenance costs due to reciprocating plunger design

PRODUCT SPECIFICATIONS

	MC250	MC350
Operating Weight	202 lb.	190 lb.
Transport Height	36.5"	36.5"
Width	21.5"	21.5"
Length with Form	40.75"	45"
Hopper Capacity	0.86 cubic feet	0.63 cubic feet
Engine	4 HP Honda recoil start	3 HP Honda recoil start
Fuel Capacity	2.1 qt.	0.81 qt.
Drive	Automatic centrifugal clutch; belt drive to enclosed gear reducer; final drive chain and sprocket	Belt drive to enclosed gear reducer; final drive chain and sprocket
Extrusion Mechanism	4" diameter extrusion auger	6" reciprocating plunger
Tires	(3) - x 3.50-4 pneumatic	



NEW WIDE-MOUTH HOPPER **Accepts a Standard Width Wheelbarrow**



Wheelbarrow Hopper

- 27% wider side opening
- 25% greater capacity in cubic feet
- 6" longer overall front to rear
- Overall machine dimensions are unchanged

*Now standard equipment on all
MC550, MC650 and MC850 models*

*Fits most models in the field
with no modifications required*

Compare the Difference

Reversible Hopper



**NOTE: The Wheelbarrow Hopper is not reversible between right and left hand extrusion.
The Reversible Hopper is still available at no additional cost upon request by ordering part # 45013-01**



Exported By:

J.D. Honigberg International, Inc
Deerfield, IL - USA
1-224-804-6025 – sales@jdhintl.com

