

# A-3SCW/A-4SCW/A-5SCW Multiple Drill, Self Propelled On Slab Unit

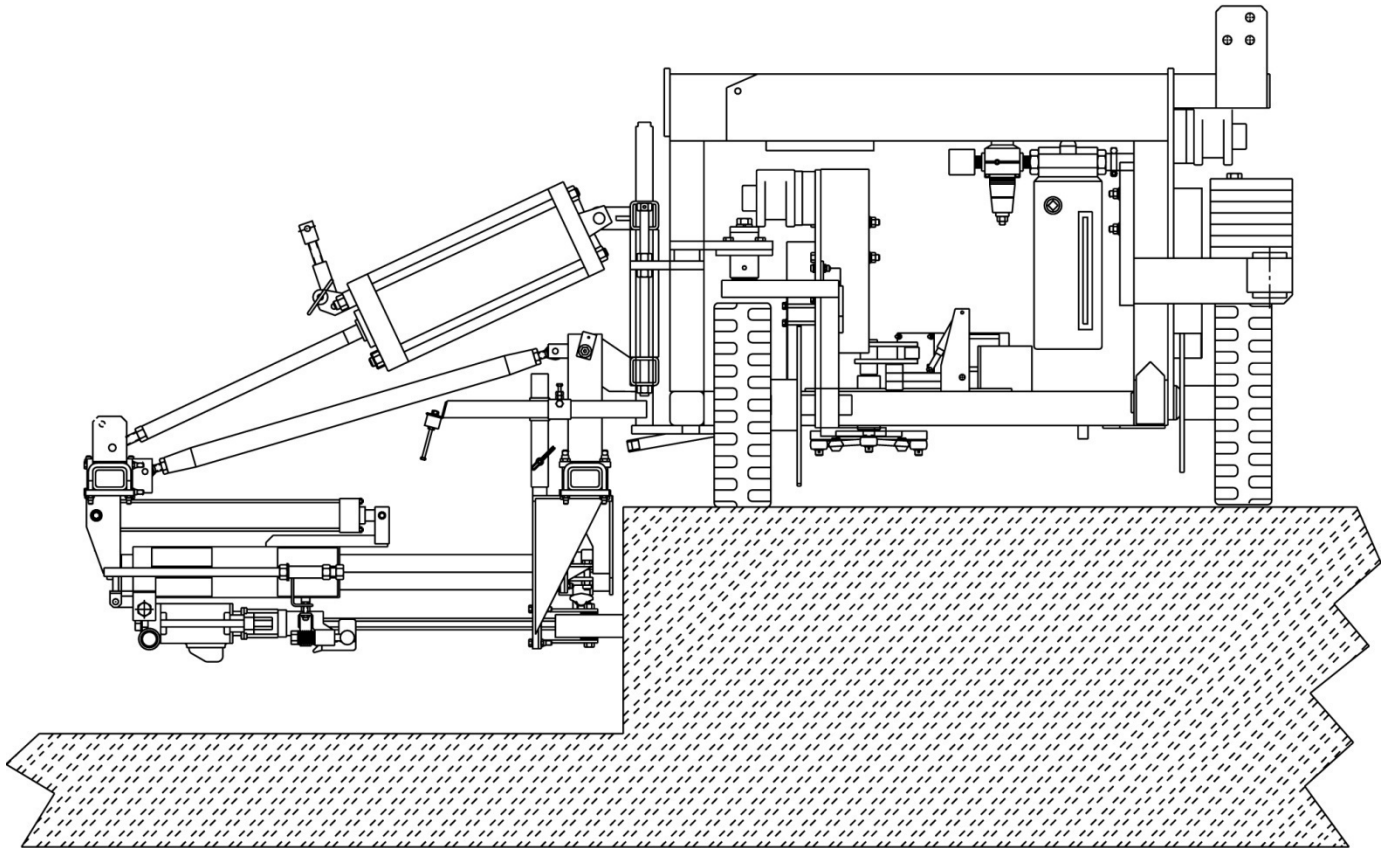

Model	A-3SCW/A-4SCW/ A-5SCW
Drill Steel Shank	.875" x 4.25" (22.2mm x 107.9mm)
Drill Steel Length U.C.	24" (61.0cm)
Drill Bit Diameter	.625" – 2.50" (15.9mm to 63.5mm)
*Maximum Drill Depth	18" (45.7cm)
Drill Distance From Top of Slab	3.5" – 12" (8.9cm to 30.5cm)
Minimum Cutout Width	48" (121.9cm)
SCFM Required Per Drill	92.2 (43.5D m <sup>3</sup> /sec)
PSIG Required	110 (7.58 BAR)
Weight A-3SCW (basic)	2860lbs. (1297kg)
Weight A-4SCW (basic)	3260lbs. (1433kg)
Weight A-5SCW (basic)	3460lbs. (1569kg)

**Horizontal and Vertical drilling**  
**Skew drill bed is available on the A-4SCW**  
**On grade kit is available**  
**Capable of towing air compressor**  
**Power crab steering**  
**Power steering**  
**Power brakes**  
**Hole Spacing Pointer**  
**Solid rubber tires**  
**Adjustable drill height, depth and centers**  
**Auto control**  
**Dust collection is available**

*Specifications shown are standard. Variations to the standard are available.*

*\*Based on 2 piece steel and bits. Whirlybits should be 1" (2.5cm) longer for maximum drilling depth.*