



**MODEL A-3/A-5  
MOUNTED AIR DRILL**

MODEL A-3 - 3 DRILL UNIT  
MODEL A-5 - 5 DRILL UNIT

SHANK SIZE..... 0.875" x 4.25"  
 DRILL BIT DIAMETER..... 0.625" TO 2.5"  
 SCFM REQUIRED PER DRILL..... 92.2 SCFM  
 PSIG REQUIRED..... 90 PSIG  
 ROTATION..... 180 RPM  
 WEIGHT A-3 (BASIC)..... 1500 LBS.  
 WEIGHT A-5 (BASIC)..... 2000 LBS.

OPTIONAL SIDE SHIFT FOR SHIFTING DRILL POSITION AVAILABLE.

DRILL DISTANCE FROM TOP OF SLAB MINIMUM - 3.00"  
 DRILL DISTANCE FROM TOP OF SLAB MAXIMUM - 12.00"

STROKE CYLINDER	STEEL LENGTH UNDER COLLAR	* DRILL DEPTH	MINIMUM CUTOUT WIDTH
20"	24"	18"	48"

\* BASED ON 2 PIECE STEEL AND BITS

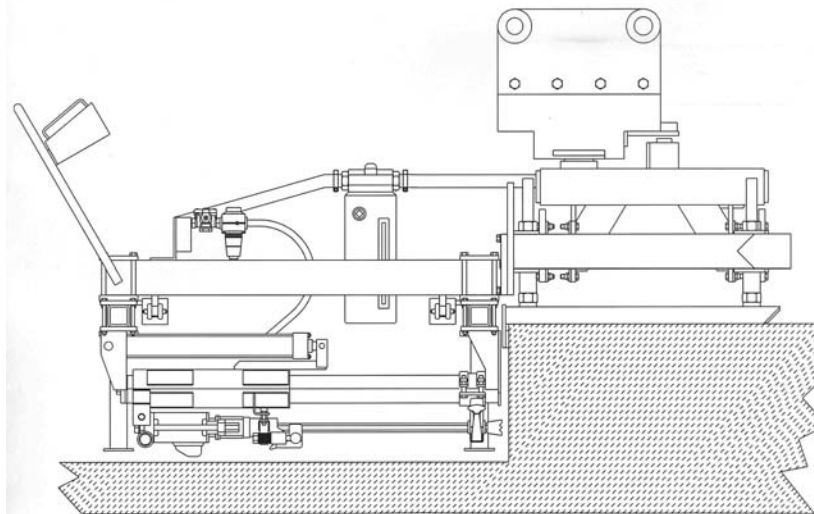

**SPECIFICATIONS ON THE UNITS SHOWN ABOVE ARE STANDARD.  
VARIATION TO STANDARD IS AVAILABLE.**

277 N. MAIN ST. - P O BOX 367 - MANSFIELD, OH 44901  
 PHONE: (419) 524-1000 - FAX: (419) 524-4000