

A-1 AIR DRILLS

	A-1-48	A-1-36	A-1-30	A-1-24
DRILL STEEL SHANK SIZE	.875" x 4.25"	.875" x 4.25"	.875" x 3.25"	.875" x 3.25"
DRILL STEEL LENGTH	24"	12"	12"	8"
DRILL BIT DIAMETER	.625" - 2.50"	.625" - 2.50"	.625" - 1.625"	.625" - 1.00"
MAXIMUM HOLE DEPTH	18"	10"	10"	7"
MINIMUM CUTOUT WIDTH	48"	36"	30"	24"
DISTANCE FROM TOP OF SLAB	3" - 12"	3" - 12"	3" - 12"	3" - 12"
REQUIRED SCFM	92.2	92.2	75	36
REQUIRED PSIG	90	90	90	90
ROTATION	180 RPM	180 RPM	240 RPM	N/A
WEIGHT	200 LBS.	185 LBS.	170 LBS.	150 LBS.

*** BASED ON 2 PIECE STEEL AND BITS**

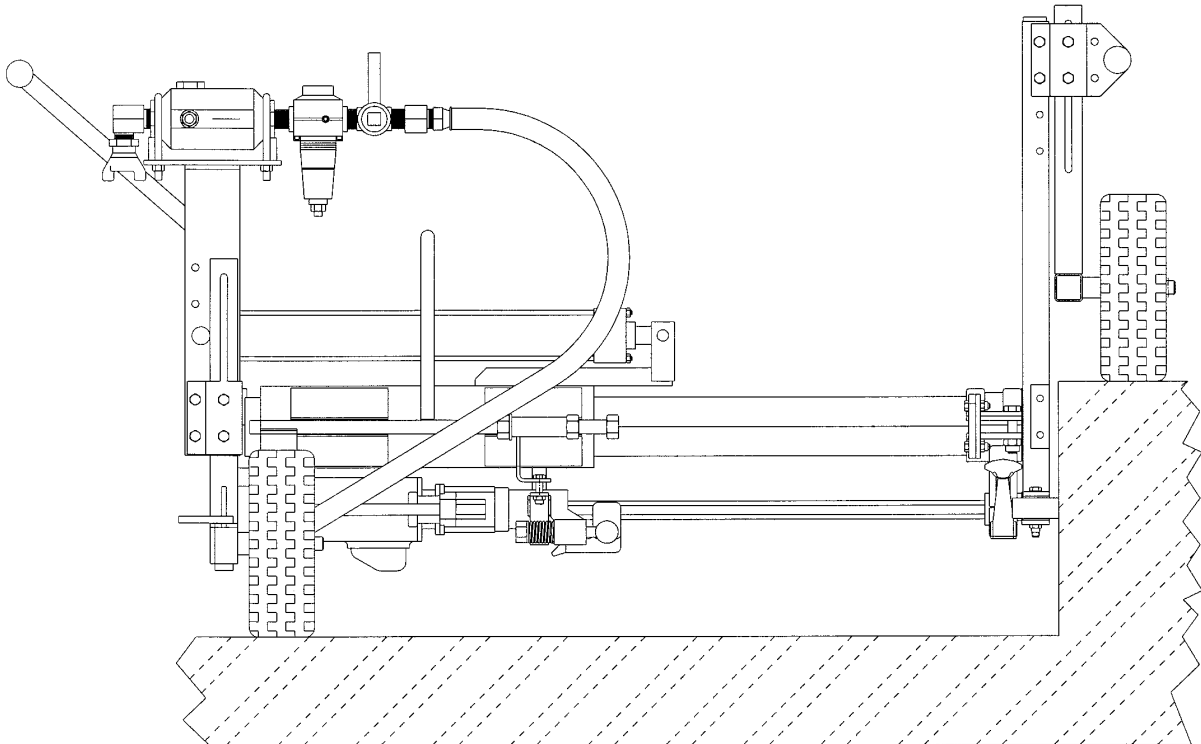

**SPECIFICATIONS ON THE UNITS SHOWN ABOVE ARE STANDARD.
VARIATION TO STANDARD IS AVAILABLE.**

277 N. MAIN ST. - P O BOX 367 - MANSFIELD, OH 44901
PHONE: (419) 524-1000 - FAX: (419) 524-4000