

SELICK

STT80

Tow Forklift

TIER 4i



The Sellick STT80 rough terrain tow forklift

Powerful

Safe

Rugged



STT80 rough terrain tow forklift

13 000 lbs capacity @ 12" load centre

ENGINE



Ecomax T4i Tier 4 compliant, low noise, 4-cylinder, turbocharged, diesel engine.

No diesel particulate filter (DPF) or selective catalyst reduction (SCR) is required providing cost savings for servicing and less downtime over other Tier 4 compliant engines equipped with a DPF and SCR.

- No SCR also means ADBLUE® is also not required providing further savings
- 74 hp provides 243 ft. lbs of torque at 1,100 rpm
- Dual element air filter
- Water separator
- Maintenance-free precleaner
- Fuel capacity: 26 gallons (98 L)

TRANSMISSION

- Fully automatic Powershift transmission.

AXLES

- **Drive:** Torque proportioning four-pinion differential with positive retraction brakes
- **2WD Steer:** Pin mounted, oscillating axle with sealed tapered roller bearings. Oscillation: 14°
- **Optional 4WD:** Outboard planetary with torque proportioning differential. On-the-go engagement.

OPERATOR COMPARTMENT

- Fully isolated, rubber-mounted operator's compartment meets or exceeds ANSI B56.6 FOPS standard.
- Adjustable suspension seat with retractable seatbelt
- Tilt steering column complete with shifter assembly and full instrumentation
- Cupholder, latched operator's manual compartment.
- Windshield wiper
- Turn signals

STEERING

- Load sense power steering with hydraulic pump assistance.
Turns: 4.5 lock to lock

BRAKE SYSTEM

- **Service brake:** Power-assisted braking system with enclosed oil-immersed multi-disc service brakes.
- **Parking brake:** Automotive style parking brake, mechanical-operated, lever-applied, operator adjusted

INSTRUMENTS

- Hour meter in center of steering console
- Full instrument cluster includes water in fuel; air restriction indicator lights

HYDRAULICS

- Cast iron load sense hydraulic pump
- A positive-pressure hydraulic tank prevents impurities from entering the system.
- Tank capacity: 21 gallons (79 L)
Hydraulic flow: 24 gpm @ 2200 rpm

MAST

- Slider-style, no bearing mast design minimizes need for adjustment and maintenance
- 2 5/16" ball mounted to slider mast.
- Control handles provide lift and sideshift functions. Sideshift: 6" total

OPTIONAL EQUIPMENT

- Block heater
- AM/FM MP3 player
- Outside rear-view mirrors
- Forks & attachments

STT80 rough terrain tow forklift

13 000 lbs capacity @ 12" load centre

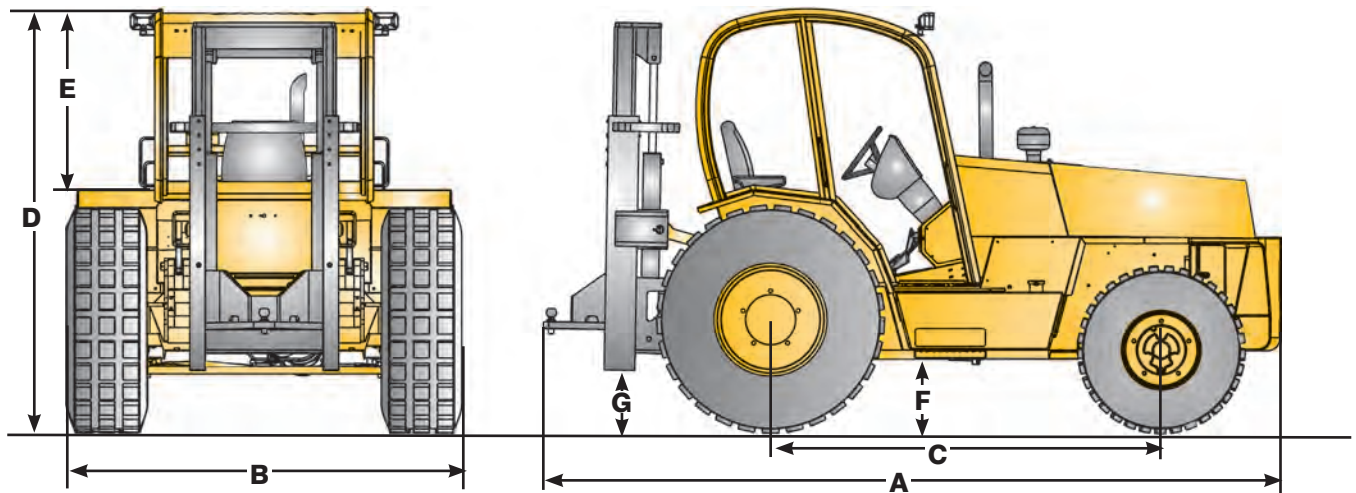

Model	Ref	STT80
Lift capacities @ 12 inch load centre		13 000 lbs/5 897 kg
Overall length	A	162"/4 115 mm
Overall width	B	89"/2 261 mm
Wheelbase	C	89"/2 261 mm
Height to top of overhead guard (std)	D	95"/2 413 mm
Distance from seat to overhead guard (std)	E	43"/1 092 mm
Outside turning radius		178"/4 521 mm
Frame underclearance	F	15"/381 mm
Mast underclearance	G	12"/305 mm
Mast sideshift		6"/152 mm
Travel speed (standard)		20 mph
Gradeability		25%
Tire size type & size (standard)		Front/Rear (pneumatic) 15.5 x 25 - 16 ply L3 ; 14 x 17.5 - 14 ply
Electrical System		Alternator - 95A; Battery 1 000 CCA (12 volt system)
Engine model		Ecomax T4i diesel turbocharged
Cylinders		4
Engine output (gross power)		74 hp @ 2 200 rpm
Peak torque		243 ft·lbs @ 1 100 rpm
Transmission type		Power reversing powershift
Noise level at operator's ear (at engine idle)		72 dba
Noise level at operator's ear (at full rpm)		88 dba
Forklift weight (unladen)		14 525 lbs/6 588 kg

Because of our constant dedication to product improvement, all specifications are subject to change without notice.



— All Sellick forklifts meet or exceed all ANSI B56.6 safety standards. —

www.sellickequipment.com

TIER 4i



Quality & Performance

The STT80 tow forklift provides exceptional quality with the following key features:

- Standard powershift transmission
- Comfortable & ergonomic cab design increases operator productivity while reducing fatigue
- Ecomax T4i Tier 4 compliant turbocharged engine provides 74 hp and 243 ft. lbs of torque
- Optional 4WD
- Multi-plate service brake provides reliable braking under any load
- 13 000 lb lift capacity at 12" load centre for lifting & towing loads of all sizes and 90° hitch access with high visibility
- Long wheelbase for smoother ride

Working for you

Built in the Sellick tradition of quality & reliability, the STT80 is supported by a network of long-established material handling dealers that provide prompt parts and service. All Sellick products are backed by one of the best warranties in the business.

setting the standard

Sold & serviced by:

SELICK

Sellick Equipment Limited
P.O. Box 1000/358 Erie Street North
Harrow, Ontario, Canada N0R 1G0
519-738-2255 • sellick@mnsi.net
www.sellickequipment.com

