

# THE TITAN™

Heavy-Duty Front Loader



*"Its solid reliability is very impressive."*

## Best value in a commercial and residential front loader.

The Titan lives up to its name ... powerful and mighty. Here's a mid-weight, strong-performance front loader perfect for commercial waste. The right specs here make for a great value and a proven performer.

### Standard Features:

- fully-proportional joystick control with feathering action
- ultra-high strength-to-weight ratio
- curved shell for superior compaction
- innovative bolt-on arm for improved maintenance
- long-life, torque-tube arm bearings (steel on steel)
- Rear camera (5" color LCD)



Front forks load rated for 8,000 lbs.



Automatic cam-over-latch tailgate locking mechanism activated from cab



12 cu. yd. hopper with wind screen

**WAYNE®**  
ENGINEERED FOR PERFORMANCE  
[www.WayneUSA.com](http://www.WayneUSA.com)

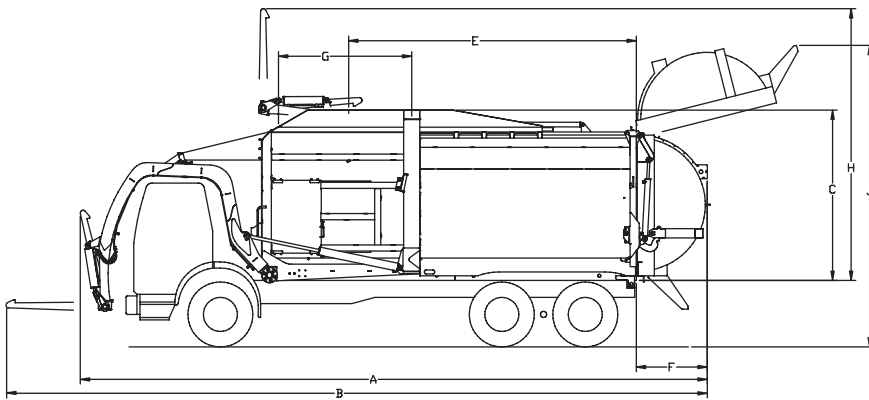

### Standard Features

- Hopper front screen
- Hopper wind screen
- Sliding access door w/ladder (streetside)
- Bolt-on arm with 8,000 lb. lift 4.5" cylinders
- (2) 12" arm torque tube bearings
- 1½" thick, 43" long forks
- Roof access ladder (curbside)
- Automatic cam-over-latch tailgate locking system
- Adjustable "up arm" deceleration valve
- Full eject design
- Cab shield with hinged extension
- Conspicuity tape and mud flaps

### Body

- Main body floor — ⅜" ASTM A715-80
- Main body sides — 10 gauge ASTM 715-80
- Tailgate volume — 5.5 yds.
- Tailgate construction — 10 gauge ASTM A715-80

### Hopper

- Floor — ¼" AR 400
- Sides (lower and upper) — ⅜" AR400
- Volume — 12 yds.

### Packer Panel

- Lower face — ¼" 100,000 PSI
- Upper face — ⅜" ASTM A715-80 100,000 PSI

### Lighting

- FMVSS compliant

### Arms and Forks

- Arms load rated 8,000 lbs
- Torque tube bearings — steel on steel
- Forks — ASTM A514

### Controls, Warning and Lockouts

- Joysticks — fully proportional with feathering action
- Sliding top door interlock standard
- Pack panel interlock standard
- Access door interlock standard

### Hydraulic System

- Hydraulic pump — 55 GPM at 1,500 RPM
- Reservoir capacity — 50 gal. (228 liters)
- Suction strainer — 100 mesh
- Return filter — 10 micron
- Burst pressure for all hoses — 4 times system working pressure
- Hydraulic tubing — large diameter, seamless, mandrel-bent tubing
- System working pressure — 2,500 PSI max

### BODY SPECIFICATIONS

40 cu. yd.

A: O.A. length, forks up	406"
B: O.A. length, forks down	455"
O.A. length, tailgate up, forks down	512"
C: O.A. height above frame, body height	110"
H: O.A. height above frame, forks & tailgate up	176"
Weight	17,360 lbs.
E: Pack panel travel	186"
Packer panel cycle	35 sec.
Full ejection of packed material	31 sec.
O.A. width	101 ½"
F: Tailgate length	46"
G: Hopper opening length	86"
Hopper opening width	79 ¾"
Hopper access door height	32 ½"
Hopper access door width	24 ½"
Max. vehicle height – 8 yd. can, arms up	235"*
Max. vehicle height – 6 yd. can, arms up	228"*
Max. vehicle height – 4 yd. can, arms up	218"*
Min. vehicle height – arms raised, no can	161 ½"*
J: Max. vehicle height – tailgate fully opened	194"
Arm cycle	17 sec.
Tailgate opening	10 sec.
Packing force	133,000 lbs

### Minimum chassis requirements:

- Front axle capacity: 20,000 lbs
- Rear axle capacity: 46,000 lbs
- Truck GVWR (recommended): 66,000 lbs
- CT (recommended): 191" (to center of trunnion)

### J.D. Honigberg International, Inc.

650 Dundee Road, Suite 150

Northbrook, IL 60062 USA

Tel: 847-412-0200

Email: [powerequipment@jdhintl.com](mailto:powerequipment@jdhintl.com)

[www.jdhpowerequipment.com](http://www.jdhpowerequipment.com)

**WAYNE®**  
ENGINEERED FOR PERFORMANCE

701 Performance Drive, Cedar Falls, IA 50613

Phone: (319) 266-1721 • Fax: (319) 266-8207

Tollfree: 888-66WAYNE

[www.WayneUSA.com](http://www.WayneUSA.com)