

QUANTUM™

Small-Body Rear Loader



"Container handling is extremely easy."

A new small-body rear loader with the most impressive performance features ever.

The new Quantum is light years ahead of any other small rear loader on the market. This high-performance unit is built to readily accept commercial container handling options as well as conventional cart tippers. The packer plate sweeps the entire tailgate for fast, complete cycling. Unique packing mechanism produces high compaction ratings and superb weight distribution.

Standard Features:

- 6 to 10 cu. yd. body capacities
- 800-900 lbs./yd³ compaction ratings
- 13 sec. cycle times
- unique tailgate design — no slide blocks
- large 1 cu. yd. hopper
- lightest body in its class
- handles 1 to 6 cu. yd. commercial containers
- 70" wide hopper opening



Automatic tailgate locking mechanism



Handles commercial containers up to 6 cu. yds.

WAYNE®
ENGINEERED FOR PERFORMANCE
www.WayneUSA.com

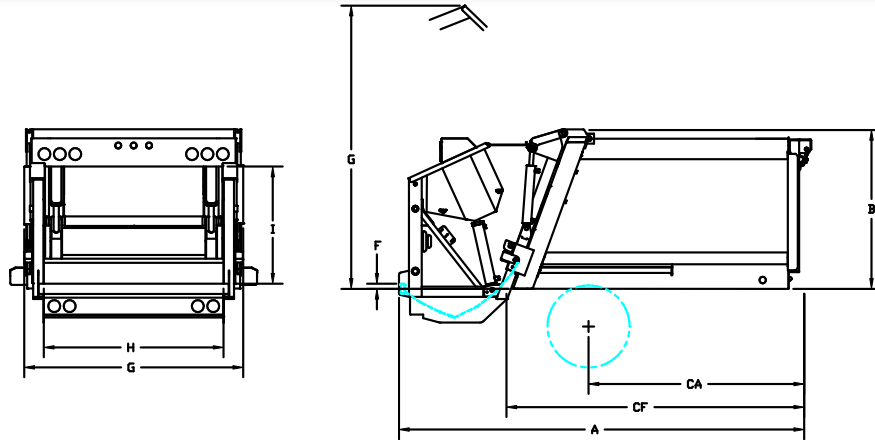

BODY SPECIFICATIONS

Advertised Body Size	6 cu. yd.	8 cu. yd.	10 cu. yd.
A: Overall Length	158"	182"	200"
B: Height Above Chassis Frame	62"		
C: Body Width	83"		
D: Hopper Opening Width	70"		
E: Hopper Opening Height	45"		
F: Loading Sill Above Chassis Frame	2"		
G: Height of Tailgate Above Chassis Frame	110" (Tailgate Raised)		
CA: Cab to Axle	84"	108"	120"
CF: Min. Usable Cab to End of Frame	116"	140"	152"
Dynamic Hopper Capacity (cu. yd./min)	4.5 cu. yd.		
Volumetric Hopper Capacity	1.0 cu. yd.		
Volumetric Hopper Capacity With CLD	1.1 cu. yd.		
Approx. Body Weight	5520 lbs.	5820 lbs.	6150 lbs.
Truck GVWR Recommended	17500 lbs.	19500 lbs.	21000 lbs.
Pack Cycle Time	13 Seconds		

Body Construction

- Roof — 11 gauge GR 50
- Sides — 11 gauge GR 50
- Floor — 11 gauge GR 50
- Ejection Panel — 11 gauge GR 50
- Sweep Face — 3/16" GR 100
- Tailgate Side Wall — 11 gauge GR 50
- Tailgate Floor — 3/16" GR 100

Features

- High strength curved shell body
- Patented packing mechanism
- Rear fenders standard
- Curved floor provides liquid sump
- Low body height
- Easy to maintain

Hydraulic System

- Oil Reservoir — 20 gal. (75.7 liters)
- Oil Flow w/ Standard Pump — 22 GPM
- Operating Pressure — 2,700 PSI
- Engine RPM — 1,300 RPM
- Hose Burst Ratio — 4:1
- Return Filter — 10 micron
- Pack Cylinders — 3.5 x 20" stroke
- Sweep Cylinders — 3.5 x 10" stroke
- Eject Cylinder
 - 6 cu. yd. — 3.5, 2 stage telescopic
 - 8 cu. yd. — 4.5, 3 stage telescopic
 - 10 cu. yd. — 4.5, 3 stage telescopic
- Tailgate Lift — 3 x 18" stroke

Optional Features

- Container roll bar with lip-and-latch
- Container lip-and-latch with 8,000 lb. drum winch
- Container roll bar with lip-and-latch and winch
- Single or dual cart tipper
- Cart tipper tap-in kits
- Work lights
- Strobe lights
- Broom and shovel holder
- Rear view color camera system

J.D. Honigberg International, Inc.

650 Dundee Road, Suite 150
Northbrook, IL 60062 USA
Tel: 847-412-0200

Email: powerequipment@jdhintl.com
www.jdhpowerequipment.com

WAYNE®

ENGINEERED FOR PERFORMANCE

701 Performance Drive, Cedar Falls, IA 50613
Phone: (319) 266-1721 • Fax: (319) 266-8207

Tollfree: 888-66WAYNE
www.WayneUSA.com