

PHOENIX™

Heavy-Duty Rear Loader



"Heavy duty all the way through."

A high-compaction, heavy-duty rear loader ideal for all commercial routes.

The Phoenix combines a rugged body with a unique in-line packing design. Now 100% of tailgate packing forces are transferred directly to load compaction. The result is higher compaction ratings with greater load density distributed end to end. Add the automated, Arlock container handling system — you're ready to tackle every commercial route with unmatched speed and operator safety.

Standard Features:

- 20 to 32 cu. yd. capacities
- 100% in-line directional packing
- ultra-high strength-to-weight ratio
- integrated resistance circuit for consistent packing
- rear camera (5" color LCD)
- trough-guided eject panel with liquid sump
- angled eject cylinder located above body floor
- 1000-plus lbs./yd. compaction rating



Arlock — the automated container handling option for safer, more productive commercial collections



Arlock shown with optional cart tipper

WAYNE®
ENGINEERED FOR PERFORMANCE
www.WayneUSA.com

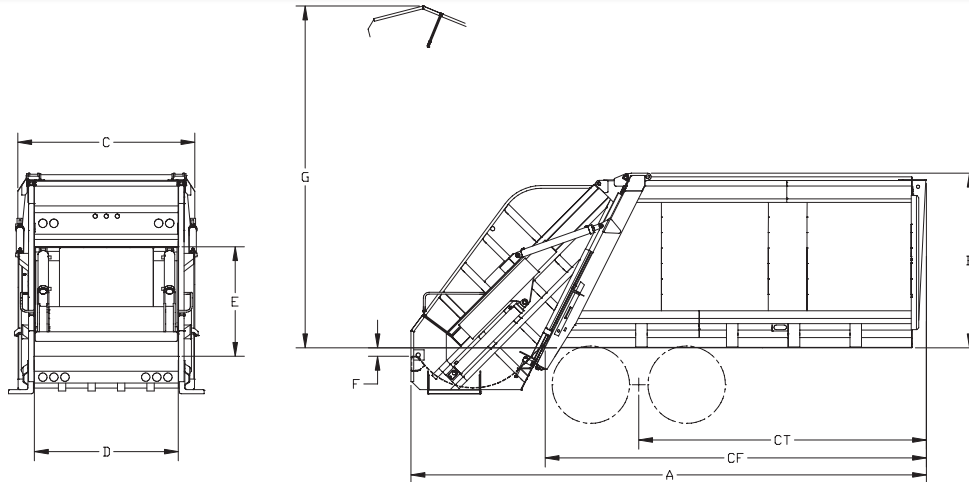

BODY SPECIFICATIONS

	20 cu. yd.	25 cu. yd.	32 cu. yd.
A: Overall Length	244"	280"	324"
B: Height Above Chassis Frame	95"	95"	95"
C: Body Width	96"	96"	96"
D: Hopper Opening Width	78"	78"	78"
E: Hopper Opening Height	68"	68"	68"
F: Loading Sill Below Chassis Frame	4.6"	4.6"	4.6"
G: Height Above Chassis Frame – Tailgate Raised	182"	182"	182"
CT: Cab to Tandem	120"	156"	200"
CF: Min. Usable CAT to End of Frame	171"	207"	251"
Dynamic Hopper Capacity (cu. yd./min.)	6.5	6.5	6.5
Volumetric Hopper Capacity	3	3	3
Volumetric Hopper Capacity w/CLD	3.3	3.3	3.3
Approx. Body Weight	14,700 lb.	15,300 lb.	16,100 lb.
Truck GVWR Recommended	52,000 lb.	58,000 lb.	66,000 lb.
Pack Cycle Time	25 - 28 seconds		

Features

- Curved shell body
- Auto back-pack
- Engine accelerator
- Reservoir sight gauge
- Chrome cylinder rods
- Access door (streetside)
- Rear camera system (5" color LCD)
- Backup alarm
- Driver alert buzzer (curbside)
- High-mount rear light bar
- Work lights
- LED ANSI/DOT lighting
- Mud flaps
- 12 mo. body/24 mo. cylinder warranty

Hydraulic System

- Oil Reservoir — 50 gal.
- Oil Flow w/Standard Pump — 36 GPM
- Operating Pressure — 2,500 PSI
- Hose Burst Ratio — 4 to 1
- Return Filter — 10 micron
- Slide Cylinders — 5"
- Sweep Cylinders — 5"
- Eject Cylinder (20 yd.) — 5"
- Eject Cylinder (25 yd.) — 5 1/4"
- Tailgate Lift — 3 1/2"

Body Construction

- Roof — 10 gauge GR80
- Sides — 10 gauge GR80
- Floor — 3/16" GR100
- Ejection Panel — 7 gauge GR50

Hopper Construction

- Tailgate Upper — 12 gauge GR50
- Tailgate Lower — 3/16" GR100
- Tailgate Floor — 1/4" AR400
- Sweep Face — 1/4" AR400

Options

- 12,000 lb. reeving winch
- 8,000 or 12,000 lb. overhead drum winch
- Hydraulically operated roll bar
- Single or dual cart tippers

J.D. Honigberg International, Inc.

650 Dundee Road, Suite 150
Northbrook, IL 60062 USA

Tel: 847-412-0200

Email: powerequipment@jdhintl.com

www.jdhpowerequipment.com

WAYNE®
ENGINEERED FOR PERFORMANCE

701 Performance Drive, Cedar Falls, IA 50613
Phone: (319) 266-1721 • Fax: (319) 266-8207

Tollfree: 888-66WAYNE
www.WayneUSA.com