

CURBTENDER®

Automated Side Loader



"This is the most reliable arm in the industry."

High-performance ASL with programmable container handling.

The industry's first ASL still goes by the name Curbtender. Refined, elegant, powerful and highly durable. This automated side loader just keeps getting better with proportional hydraulics and smart PLC controls.

Standard Features:

- 20 to 31 cu. yd. capacities
- ultra-strong, adjustable arm
- 2,000 lb. lift capacity with 7 ft. reach
- fast arm, fast packing
- full eject or tip-to-dump
- handles 30 to 450 gal. containers
- optional smooth, proportional control joystick
- single-function coordinated dump/return option
- dual-pressure grip selection — standard

WAYNE®
ENGINEERED FOR PERFORMANCE

www.WayneUSA.com



Rugged plastic hopper covers



PLC logic controller with performance data capture and service minders



Optional under-seat control for operating from the ground

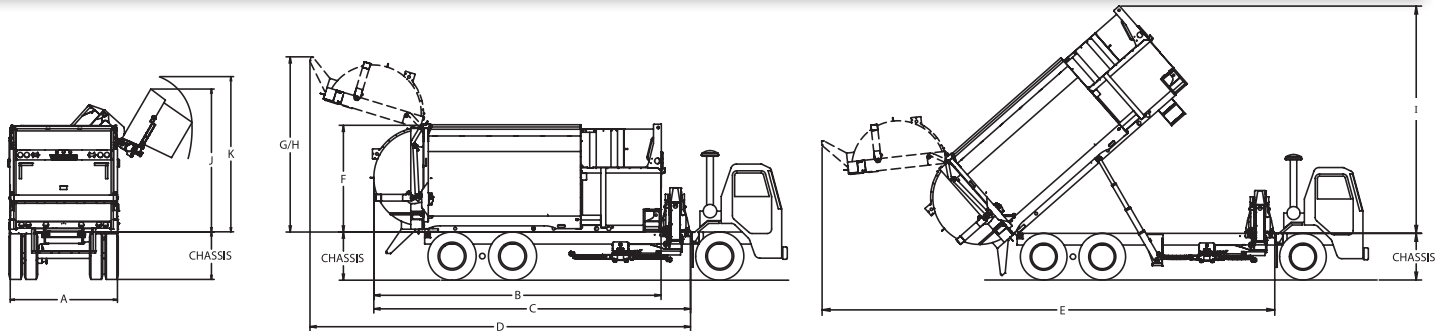

Specifications for: TTD Series (Tip-to-Dump) and FE Series (Full-Eject)

BODY SPECIFICATIONS	20 cu. yd.	24 cu. yd.	27 cu. yd.	31 cu. yd.
A: Width Overall	96" / 2,438 mm	96" / 2,438 mm	96" / 2,438 mm	96" / 2,438 mm
B: Length of Body	206" / 5,232 mm	230" / 5,842 mm	256" / 6,502 mm	278" / 7,061 mm
C: Length Lift Arm to Rear of Body	232" / 5,893 mm	256" / 6,502 mm	282" / 7,163 mm	304" / 7,722 mm
D: Length Lift Arm to Rear Door Open CTFE	262" / 6,655 mm	286" / 7,264 mm	312" / 7,925 mm	334" / 8,484 mm
E: Length Lift Arm to Rear Door Open CTTD	368" / 9,347 mm	397" / 10,083 mm	418" / 10,617 mm	443" / 11,252 mm
F: Height Above Chassis	96" / 2,438 mm	96" / 2,438 mm	96" / 2,438 mm	96" / 2,438 mm
G: Height Above Chassis Rear Door Open CTFE	157" / 3,988 mm	157" / 3,988 mm	157" / 3,988 mm	157" / 3,988 mm
H: Height Above Chassis Rear Door Open CTTD	194" / 4,928 mm	194" / 4,928 mm	194" / 4,928 mm	194" / 4,928 mm
I: Height Above Chassis Body Raised CTTD	175" / 4,445 mm	190" / 4,826 mm	207" / 5,258 mm	218" / 5,537 mm
J: Height Above Chassis Lift Arm Dump (30 – 100 gal.)	124" / 3,149 mm	124" / 3,149 mm	124" / 3,149 mm	124" / 3,149 mm
K: Height Above Chassis Lift Arm Dump (100 – 400 gal.)	135" / 3,429 mm	135" / 3,429 mm	135" / 3,429 mm	135" / 3,429 mm
Hopper Capacity	4 cu. yd. / 3 cu. m	4 cu. yd. / 3 cu. m	4 cu. yd. / 3 cu. m	4 cu. yd. / 3 cu. m
M: Approximate Body Weight	13,633 lbs.	14,149 lbs.	14,637 lbs.	15,055 lbs.

MINIMUM CHASSIS REQUIREMENTS

Minimum GVWR	36,000 lbs.	39,000 lbs.	54,000 lbs.	60,000 lbs.
Front Axle / Rear Axle	13,000 / 23,000 lbs.	14,000 / 25,000 lbs.	18,000 / 36,000 lbs.	20,000 / 40,000 lbs.
Wheel Base	177" / 4,496 mm	189" / 4,801 mm	204" / 5,182 mm	228" / 5,791 mm
Recommended CA	151" / 3,835 mm	175" / 4,445 mm	n/a	n/a
Recommended CT	n/a	n/a	180" / 4,572 mm	202" / 5,131 mm

Body Construction

- Sides: 10 gauge 50,000 PSI
- Top: 10 gauge 50,000 PSI
- Body Floor: 7 gauge GR 50
- Hopper Sides: 3/16" AR400 177,000 PSI
- Hopper Floor: 1/4" AR400 177,000 PSI

Tailgate Construction

- 10 gauge 50,000 PSI
- Raised and lowered hydraulically
- Latched and unlatched hydraulically
- Cylinders (2) 3" diameter

Packing/Ejection Cylinder

FE Series:

- Pin-to-pin mounted
- (1) double-acting telescopic
- 3 Stages for 20, 24, 27 cu. yd.
- 4 Stages for 31 cu. yd. —
6 1/2" x 5 1/4" x 4 1/4" x 3 1/4"

TTD Series:

- Pin to pin
- (1) double-acting rod
- Single stage 6"

Packing Ejection Panel

- 3/8" face sheet
- AR 400 replaceable wear shoes
- 2-piece hinged 3/16" follow panel

Hydraulics

- Tandem hydraulic pump
- 22 GPM arm, 55 GPM packer limit
- 2,500 PSI maximum system pressure
- 60 gal. hydraulic fluid reservoir
- 10 micron absolute return filter

Lift Arm Mechanism

- 2,000 lb. lift arm capacity
- 6" x 8" 50,000 PSI telescopic boom
- Adjustable roller bearing guides with AR400 wear strips
- Hardened pivot pins
- Cylinders (1) in/out 2" diameter x 66" stroke, (1) lift 2 1/2" diameter x 26" stroke, (1) dump 2 1/2" diameter x 10" stroke

Gripper

- Dual-pressure grip selection — standard
- Quick-change spring steel grippers
- Universal belt gripper (optional)
- Cylinder (1) 2 1/2" diameter x 8 1/2" stroke

Controls (all optional)

- Quik-Grip™ programmable gripper positioning
- New proportional hydraulic valve
- New proportional joystick control
- Auto shake function
- Coordinated auto-dumping

WAYNE®

J.D. Honigberg International, Inc.
 650 Dundee Road, Suite 150
 Northbrook, IL 60062 USA
 Tel: 847-412-0200
 Email: powerequipment@jdhintl.com
www.jdhpowerequipment.com