

STM Series rough terrain forklifts

5 500 or 7 000 lbs capacity @ 24" load centre

ENGINE

- Kubota V2203M naturally aspirated low noise, low emission, diesel engine
- Water separator
- Precleaner
- Single-element air filter
- Cold weather starting aid (glow plug)
- Fuel capacity: 9 gallons (34 L)

TRANSMISSION

- Hydrostatic transmission
- Full-time 3-wheel drive
- Inching control for precise load placement

OPERATOR COMPARTMENT

- Side-mount operator station provides increased visibility over loads of all sizes
- Operator's compartment meets or exceeds ANSI B56.6 FOPS/ROPS standard
- Adjustable driver's seat with retractable seatbelt
- Automotive-style controls
- Latched operator's manual compartment

INSTRUMENTS

- All-in-one dashboard instrument cluster includes hour meter/fuel gauge. Indicator lights include: Hydraulic oil temperature, air filter restriction
- Horn
- Backup alarm
- Traction control switch (improves performance on rough terrain)
- Neutral safety start

HYDRAULICS

- 5-spool hydraulic valve with easy-to-reach controls
- Stabilizers

STEERING

- Priority load sense steering

MAST ASSEMBLIES

- Corrosion resistant chain
- Lift heights to 8 ft, 10 ft and 12 ft

CARRIAGES

- 48" ITA hook Class III

ELECTRICAL

- Sealed fuse box
- Two front and one rear adjustable halogen worklights
- Safety lighting includes LED brake lights & brake lights

OPTIONAL EQUIPMENT

- Tilt steering column
- Suspension seat
- Beacon light - strobe
- Tire - 10 -16.5 10 ply

MOUNTS

- Universal easy-to-install mounts fit most truck/trailers

STM Series rough terrain forklifts

5 500 or 7 000 lbs capacity @ 24" load centre

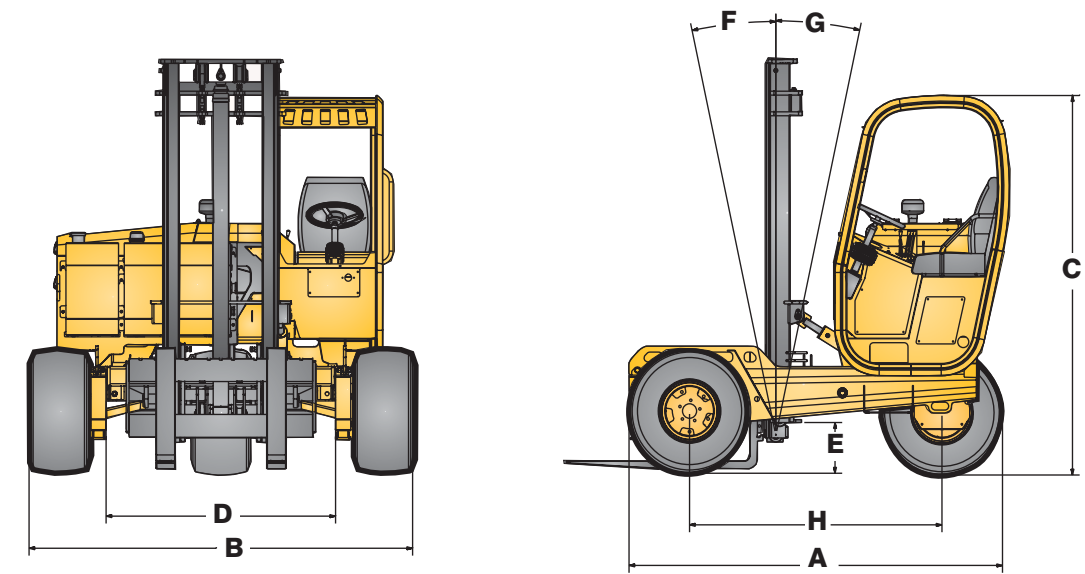

MODEL	REF	STM55	STM55P	STM55LP	STM70
Lift capacity @24" load centre		5 500 lbs/2 500 kg	5 500 lbs/2 500 kg	5 500 lbs/2 500 kg	7 000 lbs/3 175 kg
Base operating weight		6 200 lbs/2 812 kg	7 400 lbs/3 357 kg	7 200 lbs/3 266 kg	6 800 lbs/3 084 kg
Overall length (without forks)	A	95.5"/2 426 mm	105.5"/2 680 mm	105.5"/2 680 mm	105.5"/2 680 mm
Overhang		64"/1 626 mm	72"/1 829 mm	72"/1 829 mm	68"/1 727 mm
Overall width	B	100"/2 540 mm	100"/2 540 mm	100"/2 540 mm	100"/2 540 mm
Height to top of overhead guard	C	96"/2 438 mm	96"/2 438 mm	81"/2 057 mm	96"/2 438 mm
Frame opening	D			60"	
Outside turning radius				92"	
Mast sideshift				6"	
Mast underclearance	E			12"	
Mast tilt - forward	F			12°	
Mast tilt - rearward	G			10°	
Gradeability				30%	
Wheelbase	H	66"/1 676 mm	74"/1 880 mm		74"/1 880 mm
Tire size				31 - 15.5 - 15	
Engine manufacturer/model				Kubota V2203M	
Engine type				Diesel (naturally-aspirated)	
Cylinders				4	
Engine output (horsepower)				48 hp	
Transmission type				Hydrostatic	



— All Sellick forklifts meet or exceed all ANSI B56.6 safety standards. —
—www.sellickequipment.com—

J.D. Honigberg International, Inc. • 650 Dundee Road, Suite 150, Northbrook, IL 60062 USA

Tel: 847-412-0200 • Email: powerequipment@jdhintl.com • www.jdhpowerequipment.com