



## s 160 series

**Powerful  
Versatile  
Maneuverable**

The S160 Series  
16,000 lb rough terrain  
forklift

Four wheel drive

Four wheel steer

 **SELICK**

**J.D. Honigberg International, Inc.**

650 Dundee Road, Suite 150, Northbrook, IL 60062 USA

Tel: 847-412-0200 · Email: [powerequipment@jdhintl.com](mailto:powerequipment@jdhintl.com)

[www.jdhpowerequipment.com](http://www.jdhpowerequipment.com)

## Standard specifications

Explore the versatility of the new, **rugged** heavy-duty S160 Series forklift. This new addition to the popular S Series forklift line provides 16,000 lbs of lifting capacity @ 24" load centre.

## Engine

DieselMax 444 low noise, low emission, turbocharged, intercooled, four-cylinder, 114 hp, direct injection diesel engine with fuel/water separator with hand primer, dual element air filter, maintenance free pre-cleaner & vertical exhaust.

## Transmission

Three-speed fully automatic powershift transmission

## Axles

Trunnion mounted planetary axles. Internal hydraulic disc brakes, limited slip front differential provides increased traction. Integral steer cylinders. Frame leveling - 5° from centre

## Brake system

Enclosed multi-disc, oil-immersed service brakes with independent parking brake, spring applied, hydraulically released, axle mounted.

## Steering

Load sense power steering with hydraulic pump assist. 4-wheel steer

## Instruments

Full instrument package includes hour meter, water in fuel gauge and air restriction monitor.

## Mast assemblies

SEE-THRU® all-roller mast design. Internal hose routing 84" shaft carriage

## Optional equipment

- Turn signals
- Block heater
- Cab with lockable doors & tinted windows
- Full range of lift heights available
- Variety of forks available for any application
- ROPS canopy available
- AM/FM MP3 player
- Air conditioning
- Outside rear-view mirrors
- Integral sideshift
- Integral fork positioner w/ sideshift

# S160

## rough terrain forklift

Lift capacity of 16,000 lbs @ 24" load centre

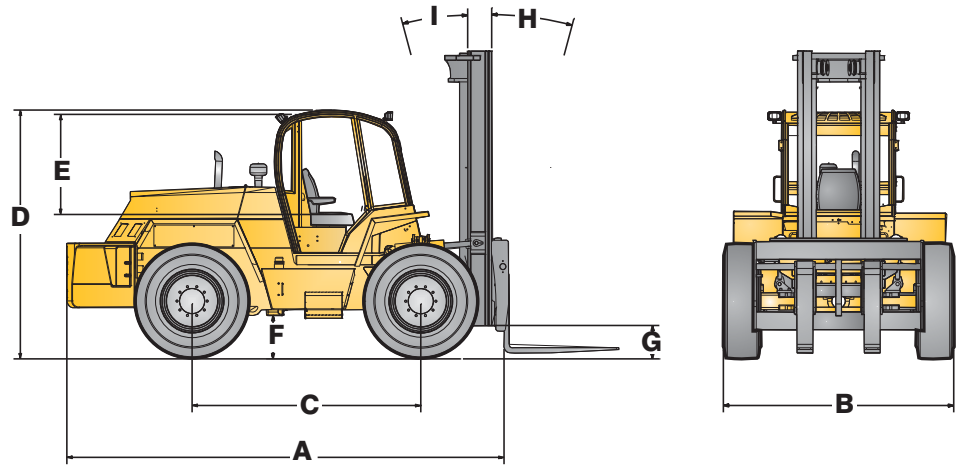

Model	Ref	S160
Lift capacities @ 24 inch load centre		16000 lbs
Overall length	A	192"/4 877 mm
Overall width	B	100"/2 540 mm
Wheelbase	C	100"/2 540 mm
Height to top of overhead guard (std)	D	107"/2 718 mm
Distance from seat to overhead guard (std)	E	43"/1 092 mm
Outside turning radius		150"/3 810 mm
Frame underclearance	F	21"/533 mm
Mast underclearance	G	12"/305 mm
Carriage sideshift		12"/305 mm
Mast tilt - forward	H	15°
Mast tilt - rearward	I	15°
Axle(s)	Dana 213 Series	
Travel speed (standard)	15 mph	
Gradeability	30%	
Tire size type & size	Front/Rear (pneumatic) 15.5 x 25 - 16 ply L3	
Electrical System	Alternator - 95A; Battery 1 000 CCA (12 volt system)	
Engine model	Dieselmax 444 Series intercooled turbocharged	
Cylinders	4	
Engine output (gross power)	114 hp @ 2200 rpm	
Peak torque	324 ft·lbs @ 1300 rpm	
Transmission manufacturer & type	Dana T20000 Automatic Powershift	

*Because of our constant dedication to product improvement, all specifications are subject to change without notice.*



**J.D. Honigberg International, Inc.**

650 Dundee Road, Suite 150

Northbrook, IL 60062 USA

Tel: 847-412-0200

Email: [powerequipment@jdhintl.com](mailto:powerequipment@jdhintl.com)

[www.jdhpowerequipment.com](http://www.jdhpowerequipment.com)

