

S Series rough terrain forklifts

6 000, 8 000, 10 000, 12 000 lbs capacity @ 24" load centre



Standard specifications

The S Series straight mast rough terrain forklift is packaged to optimize operator visibility, safety and comfort while maximizing machine performance. The one-piece frame welded construction offers rugged durability. The isolated, rubber-mounted operator's compartment is designed to reduce noise and vibration. Operators benefit from greater fork visibility and control. All controls and instrumentation are close at hand.

Engine

Dieselmax EPA-compliant low noise, low emission naturally-aspirated four-cylinder, direct injection, diesel engine, 84 hp with dual element pre-cleaner, water separator and glow plug cold weather starting aid. Torque rating 236 ft-lbs @ 1200 rpm. Fuel capacity: 26 gallons (98 L).

Transmission

Four-speed (3-speed in S120 models) synchroshuttle transmission with torque converter and integral parking brake. Optional 4WD on-the-fly engagement.

Axles

Drive: Pad-mounted rigid planetary axle, torque proportioning four-pinion differential, gears are specially-shaped to transfer torque between wheels. Positive retraction brakes.

2WD Steer: Pin-mounted, oscillating axle with sealed tapered roller bearings. Oscillation: 14°

Optional 4WD Steer: Outboard planetary with torque proportioning differential.

Operator compartment

Fully isolated, rubber-mounted operator's compartment meets or exceeds ANSI B56.6 FOPS standard. Adjustable suspension seat with retractable seatbelt, tilt steering column, cupholder, coat hook, latched operator's manual compartment, Operator's Manual, safety decal package. Optional ROPS canopy.

Brake system

Service brake: Power-assisted braking system with enclosed oil-immersed multi-disc service brakes.

Parking brake: Independent parking brake system, mechanical-operated, lever-applied, manually-adjusted caliper, mounted on transmission output shaft, disc diameter 279.4 mm (11 inches).

Steering

Load sense power steering with hydraulic pump assistance.

Steer turns: 4.75 left/3.75 right (lock to lock).

Electrical system

Voltage: 12 V; alternator: 95A; battery: 750 CCA.

Instruments

Standard indicator lights located on the steering console for easy vehicle performance monitoring. Full instrumentation includes warning indicator lights and gauges, horn and backup alarm.

Gauges: engine coolant temperature, voltmeter, fuel level, transmission temperature gauge, hour meter.

Indicator lights: low voltage, low engine oil pressure, engine coolant temperature, park brake, service brake pressure, transmission pressure, transmission temperature, preheat, water-in-fuel, air filter.

Hydraulics

Closed hydraulic system powered by cast iron load sense hydraulic pump. A positive-pressure hydraulic tank prevents impurities from entering the system.

Tank capacity: 21 gallons (79 L)

Hydraulic flow rate: 25 gpm @ 2400 rpm

Mast assemblies

Sellick SEE-THRU® all-roller design. Two- and three-stage available. Sideshift: 6" total.

Carriages

ITA hook- or shaft-type carriages equipped with 6 rollers and 4 side thrust rollers.

Standard features

- Adjustable suspension seat
- Tilt steering column
- Retractable seatbelt
- Water separator
- Engine pre-cleaner
- Power assisted enclosed wet disc brakes
- Load sense power steering
- Halogen lighting package includes two front and two rear adjustable worklights
- Safety lighting includes LED brake lights & amber warning light
- Backup alarm
- Automotive style park brake with neutral interlock
- Neutral safety start



S Series rough terrain forklifts

6000, 8000, 10000, 12000 lbs lift capacities @ 24" load centre

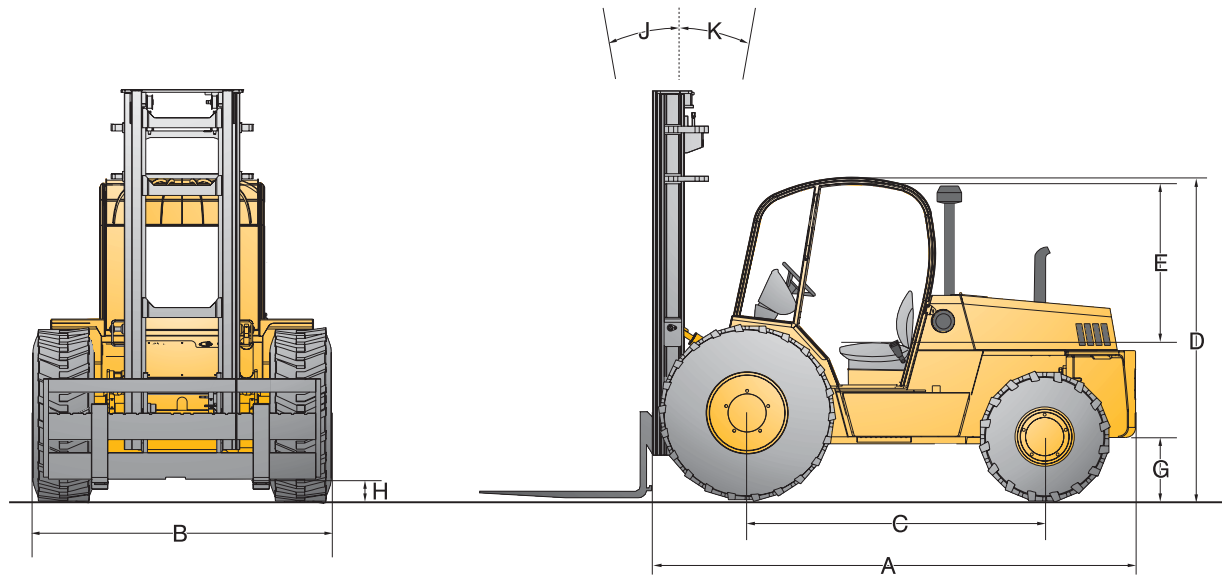

Model	Ref	S60	S80	S100	S120
Lift capacities @ 24 inch load centre		6000 lbs	8000 lbs	10000 lbs	12000 lbs
Overall length (without forks)	A	149"/3785 mm	150"/3810 mm	152"/3861 mm	159"/4039 mm
Overall width	B		89"/2261 mm		
Wheelbase	C		89"/2261 mm		
Height to top of overhead guard (std)	D		95"/2413 mm		
Distance from seat to overhead guard (std)	E		43"/1092 mm		
Outside turning radius			178"/4521 mm		183"/4648 mm
Aisle width 90° stacking			266"/6756 mm		271"/6883 mm
Frame underclearance	G		15"/381 mm		
Mast underclearance	H		12"/305 mm		
Mast sideshift			6"/152 mm		
Mast tilt - forward	J		45°		
Mast tilt - rearward	K		12°		
Travel speed (standard)		19 mph	19 mph	19 mph	12 mph
Gradeability			25%		
Tire size type & size (standard)		Drive (pneumatic) 15.5 x 25 - 12 ply			
		Steer (pneumatic) 14 x 17.5 - 14 ply			
Engine manufacturer & model		Dieselmax 444 Series diesel naturally-aspirated			
Cylinders		4			
Engine output (gross power)		84 hp @ 2200 rpm			
Peak torque		236 ft-lbs @ 1200 rpm			
Transmission type		Power reversing synchromesh			
Noise level at operator's ear (at engine idle)		74 dbA			
Noise level at operator's ear (at full rpm)		89 dbA			

Because of our constant dedication to product improvement, all specifications are subject to change without notice.

— All Sellick forklifts meet or exceed all ANSI B56.6 safety standards. —

J.D. Honigberg International, Inc.

650 Dundee Road, Suite 150, Northbrook, IL 60062 USA

Tel: 847-412-0200 · Email: powerequipment@jdhintl.com

www.jdhpowerequipment.com

SELICK
Sellick Equipment Limited