



poultry coop handlers

powerful

Work in tight quarters

The low profile SLP and S Series are specially equipped to handle the demands of the poultry industry. Poultry Coop Handlers have full lift capacity to maximum fork height to ensure operator safety, productivity and efficiency in the tightest quarters.

Exceptional performance is delivered from a high powered diesel engine coupled to a fully automatic transmission which increases productivity and reduces downtime.

All models are available in two or four-wheel drive for excellent on-command traction.



SELICK

Poultry coop handlers

Lift capacities @ 48" load centre

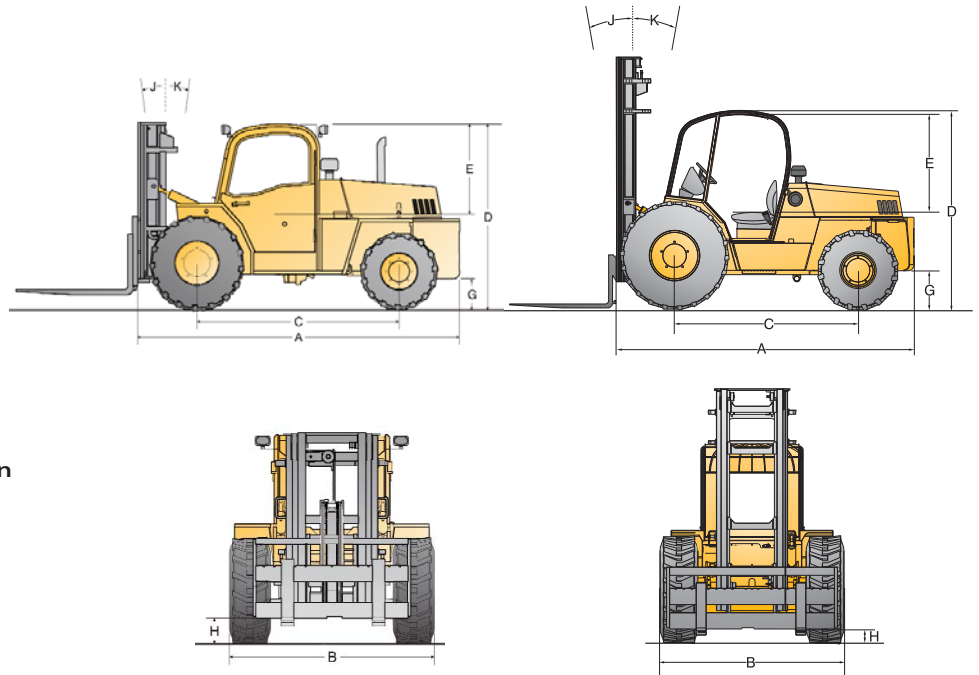

Optional equipment & attachments

Powershift automatic transmission

15° or 43° rotator carriages for pullet or broiler handling

Wide variety of forks

Model	Ref	SLP-60	S60
Lift capacities @ 48 inch load centre		3878 lbs/1,762 kg	4 200 lbs
Overall length (without forks)	A	141"/3581 mm	149"/3 785 mm
Overall width	B	78"/1981 mm	89"/2 261 mm
Wheelbase	C	87"/2 210 mm	89"/2 261 mm
Height to top of overhead guard	D	79"/2007 mm	85"/2 159 mm
Distance from seat to overhead guard	E	40"/1016 mm	40"/1016 mm
Outside turning radius	2WD 4WD	172"/4 369 mm 190"/4 826 mm	178"/4 521 mm 178"/4 521 mm
Aisle width 90° stacking	2WD 4WD	260"/6 604 mm 278"/7 061 mm	266"/6 756 mm 266"/6 756 mm
Frame underclearance	G	11"/279 mm	15"/381 mm
Mast underclearance	H	12"/203 mm	12"/305 mm
Mast sideshift		6"/152 mm	6"/152 mm
Mast tilt - forward	J	20°	45°
Mast tilt - rearward	K	10°	12°
Gradeability		25%	25%
Tire type & size (standard) Drive		15 - 19.5 - 12 ply	15.5 x 25 - 12 ply
Steer		12 - 16.5 - 10 ply	14 x 17.5 -10 ply
Engine manufacturer & model		Dieselmax 444 diesel naturally-aspirated	
Cylinders		4	
Engine output (gross power)		84 hp @ 2200 rpm	
Peak torque		236 ft-lbs @ 1200 rpm	
Transmission type (optional)		4-speed fully automatic powershift	

Because of our constant dedication to product improvement, all specifications are subject to change without notice.

— All Sellick forklifts meet or exceed all ANSI B56.6 safety standards. —

SELICK
Sellick Equipment Limited · J.D. Honigberg International, Inc.
 650 Dundee Road, Suite 150, Northbrook, IL 60062 USA
 Tel: 847-412-0200 · Email: powerequipment@jdhintl.com
www.jdhpowerequipment.com