

mm *Minnich*

CONCRETE VIBRATORS & DOWEL PIN DRILLS

A-2/A-6 Multiple Drill, Equipment Mounted Unit

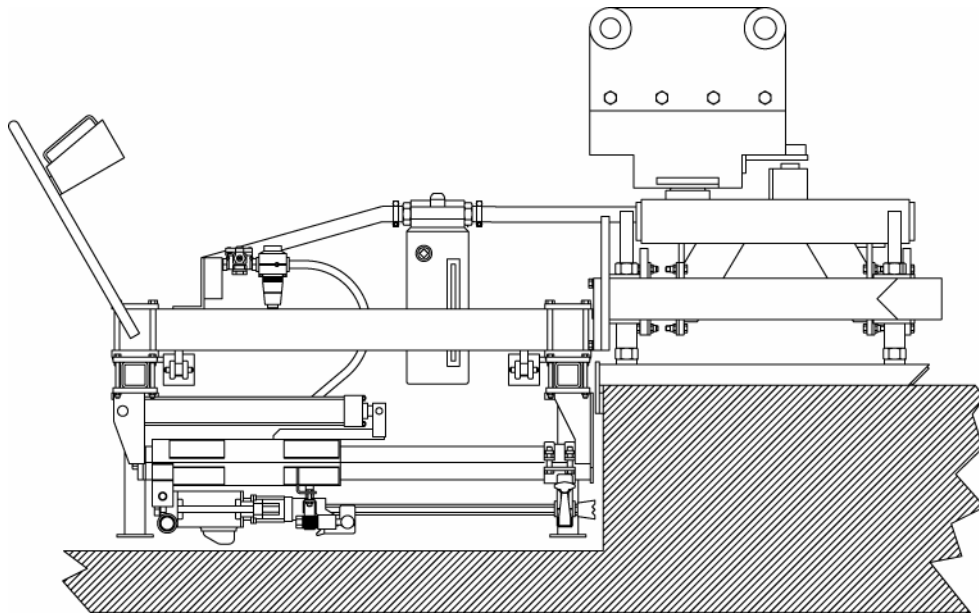

Model	A-2/A-6
Drill Steel Shank	.875" x 4.25" (22.2mm x 107.9mm)
Drill Steel Length U.C.	24" (61.0cm)
Drill Bit Diameter	.625" – 2.50" (15.9mm to 63.5mm)
*Maximum Drill Depth	18" (45.7cm)
Drill Distance From Top of Slab	3" – 12" (7.6cm to 30.5cm)
Minimum Cutout Width	48" (121.9cm)
SCFM Required Per Drill	92.2 (2.61 m ³ /min)
PSIG Required	90 (0.62MPa)
Weight A-2	1250lbs. (567.0kg)
Weight A-3	1500lbs. (680.4kg)
Weight A-4	1750lbs. (793.8kg)
Weight A-5	2000lbs. (907.2kg)
Weight A-6	2125lbs. (963.9kg)

*Side shift is standard on A-2 and A-3
Side shift is optional on A-4 thru A-6
330 degree drill bed rotation
Adjustable drill height, depth and centers
Backhoe or skid loader mounted
Dust collection is available*

*Specifications shown are standard.
Variations to the standard are available.
*Based on 2 piece steel and bits.
Whirlybits should be 1" longer for maximum drilling depth.*

J.D. Honigberg International, Inc.

650 Dundee Road, Suite 150, Northbrook, IL 60062 USA

Tel: 847-412-0200 · Email: powerequipment@jdhintl.com · www.jdhpowerequipment.com