

### A-1

## Single Drill, On Grade Unit

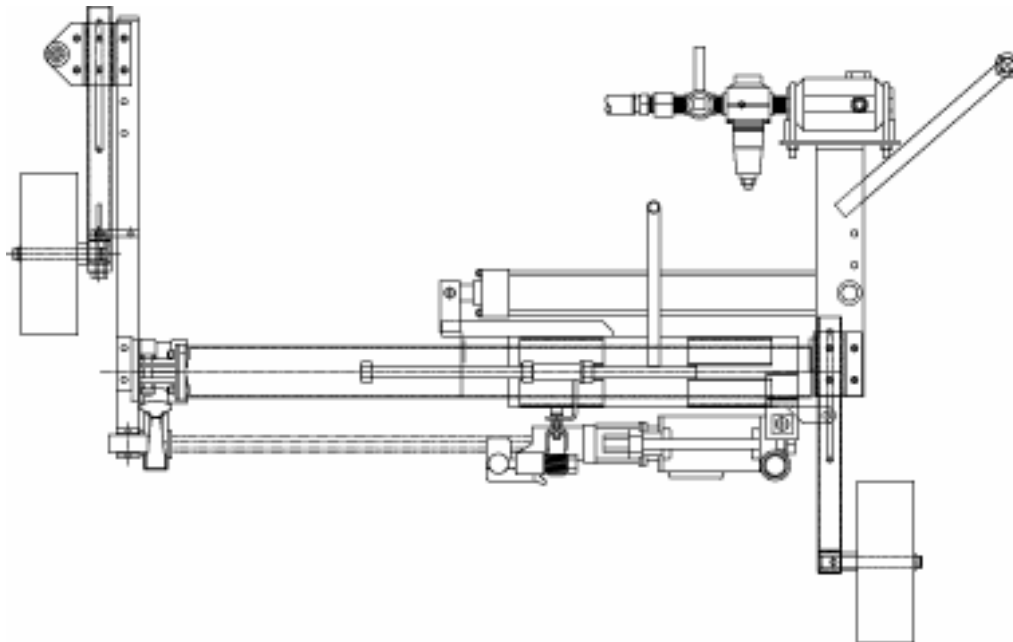

The A-1 can be configured four different ways. There is no need to purchase extra conversion kits.

1. Two wheel on grade for more accurate drilling
2. One wheel on grade for drilling 6" to corner
3. Wall configuration for zero clearance drilling
4. Vertical configuration for all vertical applications

Model	A-1-48	A-1-36	A-1-30	A-1-24
Drill Steel Shank	.875" x 4.25" (22.2mm x 107.9mm)	.875" x 4.25" (22.2mm x 107.9mm)	.875" x 3.25" (22.2mm x 82.6mm)	.875" x 3.25" (22.2mm x 82.6mm)
Drill Steel Length U.C.	24" (61.0cm)	12" (30.5cm)	12" (30.5cm)	9" (22.9cm)
Drill Bit Diameter	.625" – 2.50" (15.9mm to 63.5mm)	.625" – 2.50" (15.9mm to 63.5mm)	.625" – 1.625" (15.9mm to 41.3mm)	.625" – 1.00" (15.9mm to 25.4mm)
*Maximum Drill Depth	18" (45.7cm)	10" (25.4cm)	10" (25.4cm)	7" (17.8cm)
Drill Distance From Top of Slab	3" - 12" (7.6cm to 30.5cm)	3" - 12" (7.6cm to 30.5cm)	3" - 12" (7.6cm to 30.5cm)	3" - 12" (7.6cm to 30.5cm)
Minimum Cutout Width	48" (121.9cm)	36" (91.4cm)	30" (76.2cm)	24" (61.0cm)
SCFM Required	92.2 (2.61 m <sup>3</sup> /min)	92.2 (2.61 m <sup>3</sup> /min)	75 (2.12 m <sup>3</sup> /min)	36 (1.02 m <sup>3</sup> /min)
PSIG Required	90 (0.62MPa)	90 (0.62MPa)	90 (0.62MPa)	90 (0.62MPa)
Weight	200lbs. (90.7kg)	185lbs. (83.9kg)	170lbs. (77.1kg)	150lbs. (68.0kg)

Specifications shown are standard. Variations to the standard are available. Dust collection is available.

\*Based on 2 piece steel and bits. Whirlybits should be 1" longer for maximum drilling depth.

J.D. Honigberg International, Inc.

650 Dundee Road, Suite 150, Northbrook, IL 60062 USA

Tel: 847-412-0200 · Email: [powerequipment@jdhintl.com](mailto:powerequipment@jdhintl.com) · [www.jdhpowerequipment.com](http://www.jdhpowerequipment.com)